



TOP FOUR STROKE ENGINES

ROTO 125 FSi

OPERATING INSTRUCTIONS



CONTENTS

1. Introduction	3
2. Safety instructions	3
3. Package contents	4
4. Mounting	5
4.1 The engine mount	5
4.2 The engine	5
4.3 Carburetor	6
4.4 Fuel system	6
4.5 Waste output	7
4.6 Exhaust pipes	7
4.7 Propeller installation	8
5 Ignition	10
5.1 Ignition installation	10
5.2 Ignition power supply	10
6 Engine lubrication	11
7 Settings	12
7.1 The valves adjustment	12
7.2 Carburetor settings	14
8 Starting the engine	15
9 Spare parts	16
10 Accessories	17
11 Warranty card	18
12 Contact / technical support	

Please check the updates of the operating instructions on the website www.rotomotor.cz so that your engine always has the best care.

THANK YOU FOR CHOOSING OUR PRODUCT

**FOUR-STROKE ENGINE
PRODUCED IN THE CZECH REPUBLIC.**

1. Introduction

You have purchased a new four-stroke two-cylinder petrol engine that requires the first few important steps to successfully start your RC plane model .

The engine has already been tested and started by the manufacturer, everything is fine and it works as it should!

The engine is basically adjusted and tested with a 28/10 propeller fitting and ROTO exhausts.

2. Safety instructions

- Always be very careful when handling the engine.
- The engine can start even when the propeller rotates very slowly and injure you!
- Whenever you start the engine, make sure that you have the model secured so that there is no movement of the model and possible injury!
- Do not drive the plane with the engine running in between spectators and colleagues at the airport!
- Do not touch the engine after the flight, it is hot and there is a risk of burns!
- You have one body, take care of it and enjoy ROTO engines.



3. Package contents

Please follow the instructions carefully.

Check that all the listed parts are in the box.

Standard package contents:

1. ROTO 125 FSi 1 x
2. Ignition ROTO 125 FSi 2 x
3. Exhaust pipes 2 x
4. Waste oil hose 1 x
5. Spark plug key CM6 1 x
6. Cable ties 4 x
7. Silicone tubes 2 x



4. Mounting

4.1 The engine mount

To mount the engine in the model, we will use steel strength bolts and lock nuts.

We will use large washers under the nuts due to the pressure distribution on the engine mount, so that mount is not dented.

For the engine to work properly and its properties to be optimal, the engine must be warmed up to operating temperature.

The carburettor is set at the factory (ROTOmotor). We do not recommend any disassembly of the intake manifold or carburetor.



Periodically check the attachment of the engine to the engine bulkhead to ensure that it does not come loose.

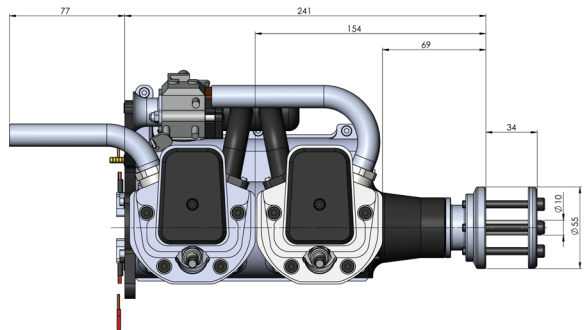
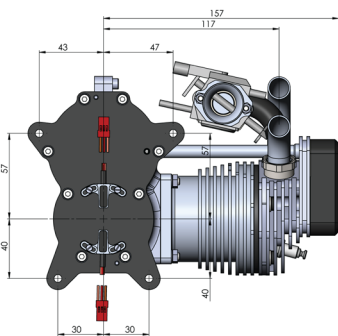

4.2 The engine

It is necessary to provide enough air to the carburetor. In case of lack of the air, the engine may have poor performance and may fluctuate at maximum speed.

It is necessary to ensure sufficient cooling of the cylinder heads and cylinders with a constant supply of air from the propeller or from the surrounding environment.

4.3 Carburetor

A suction nozzle is mounted on the carburetor. We must ensure a sufficient air supply for the correct operation of the engine. Do not cover it!



Do not remove the nozzle, do not modify it!
It's part of the engine, and the correct operation of the engine depends on it.

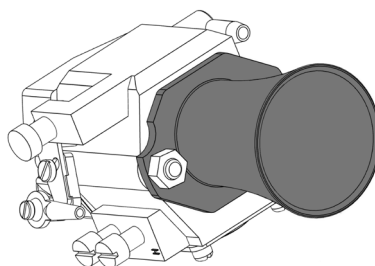

The image is for illustration purposes only

4.4 Fuel system

It is necessary to connect a hose with fuel supply to the carburetor. A protective plug is attached to the carburetor fuel fitting due to dirt during transport. This plug must be removed and the gas supply from the model's tank connected in its place.



When removing the engine from the model for a longer period of time, it is necessary to replace the protective plug to prevent the fuel in the carburetor from drying out.

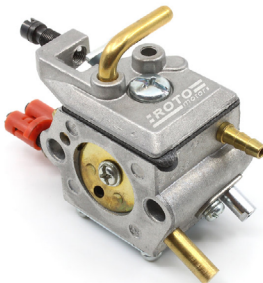

4.5 Waste output

Then install the lubrication waste oil hose on the rear cover of the engine. To seal it we use Loctite AA 326 glue or similar to seal the thread.

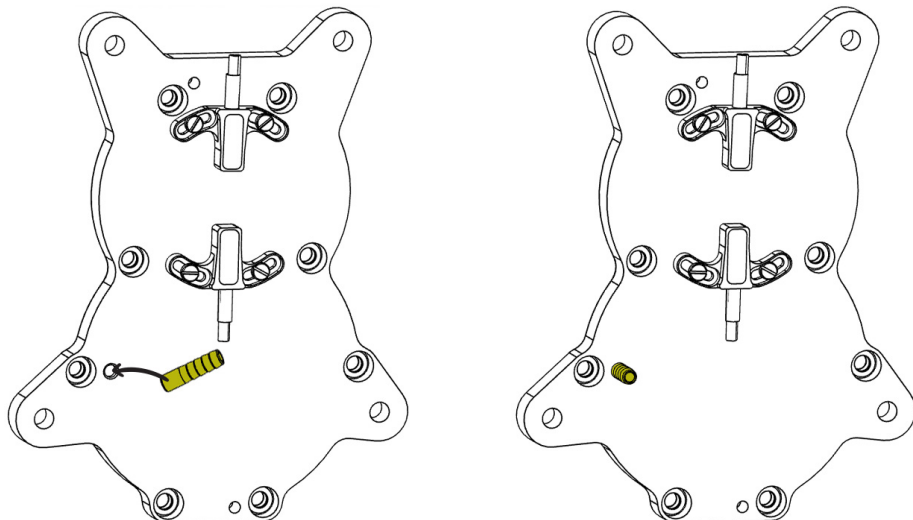
**NO TOOLS****ONLY HAND****LOCTITE AA 326****WAIT FOR
3 HOURS**

We recommend leading the waste oil hose to the landing gear.



Waste output is very important and must never be blocked.

In any case, do not reduce the diameter of the hose, otherwise the engine get damaged.

If the waste output is clogged, the motor will be damaged.

4.6 Exhaust pipes

The exhaust pipes are made so that they can be rotated around the axis. Therefore, set the exhaust pipes to the desired position by turning and then secure by tightening the nut.



The diameter of the exhaust pipe cannot be reduced!



Beware of damage to the end of the pipe!
The end of the pipe serves as a sealing surface for the extension tube. If damaged, it will not be possible to seal the pipes correctly!

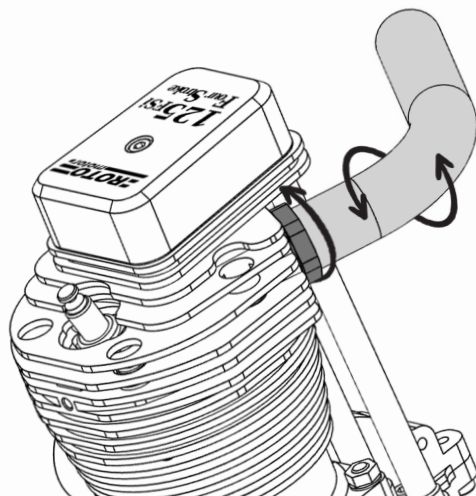

The exhaust pipes can be rotated in a small range as needed.

$\pm 10^\circ$

Silicone pipes* are used to seal the transition between the exhaust pipes and the ROTO exhausts, or between the extension pipe and the ROTO FS exhaust.

ROTO extension pipe and exhaust are not included!

When mounting on the extension pipe or exhaust, the silicone pipe* must be secured with a cable tie* on each side of the hose to seal the connection well.



The silicone pipe seals correctly only if the contact surfaces are clean and free of grease.

When reassembling, the contact surfaces must be degreased!



There should be no more than 2mm between the end of the exhaust pipe and the exhaust.

*A part of the package

4.7 Propeller installation

It is very important to mount the propeller correctly. 6 strength screws are used for this purpose. Tighten them evenly! The propeller must be regularly checked and tightened, especially when using a new wooden propeller.

Tightening torque

Carbon propeller 7 Nm
Wooden propeller 6 Nm

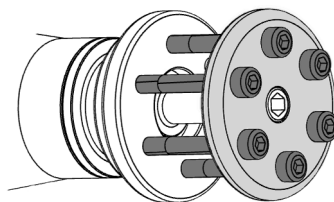

For wooden propellers, the tightening torque may vary based on the material used to make the propellers. We recommend asking the propeller manufacturer for the appropriate tightening torque!



Check the tightening of the propeller often, especially at the beginning, when the propeller is new!



Loose screws will result in shearing of the screws, exposing you to injury as well as damage to your model. This danger is especially dangerous when using a wooden propeller.

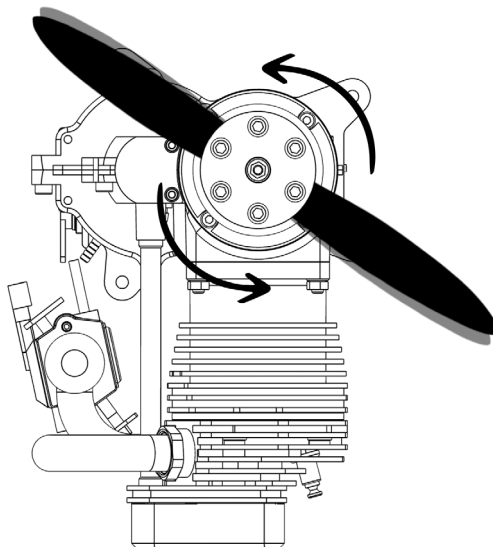

Direction of rotation of the propeller / Engine

5. Ignition

5.1 Ignition installation

Place the ignition in a suitable place where there is no risk of excessive heat from the cylinder heads or the exhaust system.

CDI also known as Ignition contains three connectors that you must connect.

- **Hall Sensor**
- **Spark plug cup**
- **Power supply**

Connect these three connectors to the motor so that the labels on the cables are identical. It is very important for the proper functioning of the engine.

For easier understanding, follow the attached wiring diagram.



Never remove the Hall sensors from the backplate.

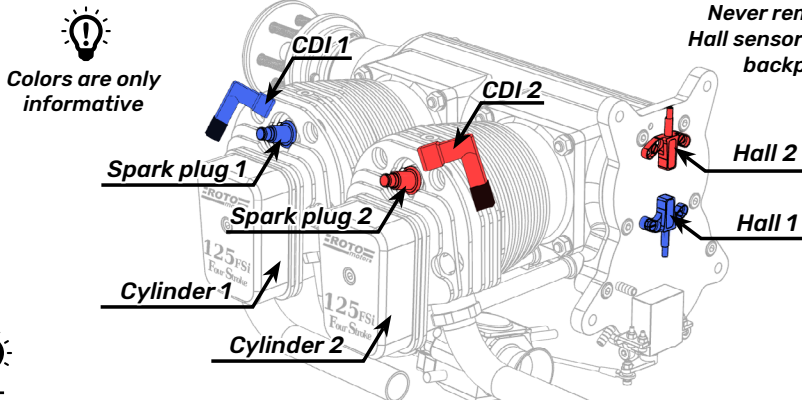

Make sure that the ignition is well and sufficiently cooled!

Do not bend the HV cables into sharp bends, they may be interrupted

Make sure that the connectors are fitted correctly and that there is no risk of loosening them!

If the ignition is heated above 60 °C, the ignition will switch off and the engine stops working.

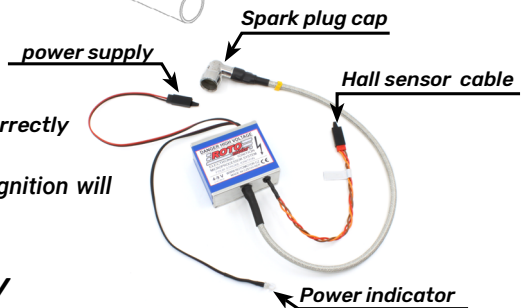

5.2 Ignition power supply

The recommended power supply for ignition is 4-9V.



**Always charge the batteries before flying.
Do not rely on charging from the last flight!**

6. Engine lubrication

Engine lubrication is provided by adding oil to gasoline in the ratio of 1:50.
For easier application, use this table:

Use gasoline **95 - 98 oct.**
+
Motul 800 oil /1:50 *or* **STIHL HP Ultra** oil /1:50



Failure to follow the recommended oil types will void your warranty.
! DANGER OF ENGINE DAMAGE!

Metric system

Fuel	Oil
L	mL
1	20
2	40
3	60
4	80
5	100
6	120

Imperial system

Fuel	Oil
gal	oz
1	2.56
2	5.12
3	7.68
4	10.24
5	12.8
6	15.36



Information about our network of dealers at info@rotomotor.cz

7. Settings

7.1 The valves adjustment

For running and long-term operation of the engine, it is necessary to check the correct valve clearance after the first 2-3 hours of operation.

To review and adjust, follow these steps:

Unscrew the rocker cover bolts on the cylinder heads and then remove the rocker covers.

We recommend also unscrewing the spark plugs so that the propeller hub can turn better.

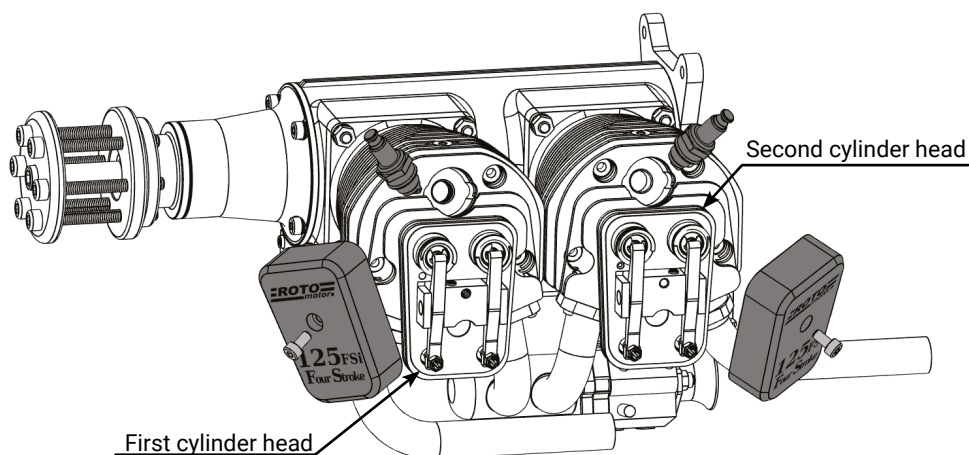

**By turning the propeller hub, is turned the crankshaft
Turn counter-clockwise**

Turn the propeller hub until the valves on the first head are at top dead center, which means they will be fully closed by the valves on the cylinder. We can tell by the fact that the valves stop moving and have clearances. Only then can you adjust the clearances on the valves

Valves adjustment:

Loosen the lock nut with a wrench and turn the screw. Set the required clearance with the help of a feeler gauge.

Then tighten the lock nut to 2.4NM

Adjusting the other cylinder head is the same turn the propeller hub until they are at top dead center on the other head then adjust these valves as well

Then complete the engine.

Adjusting the cylinder head

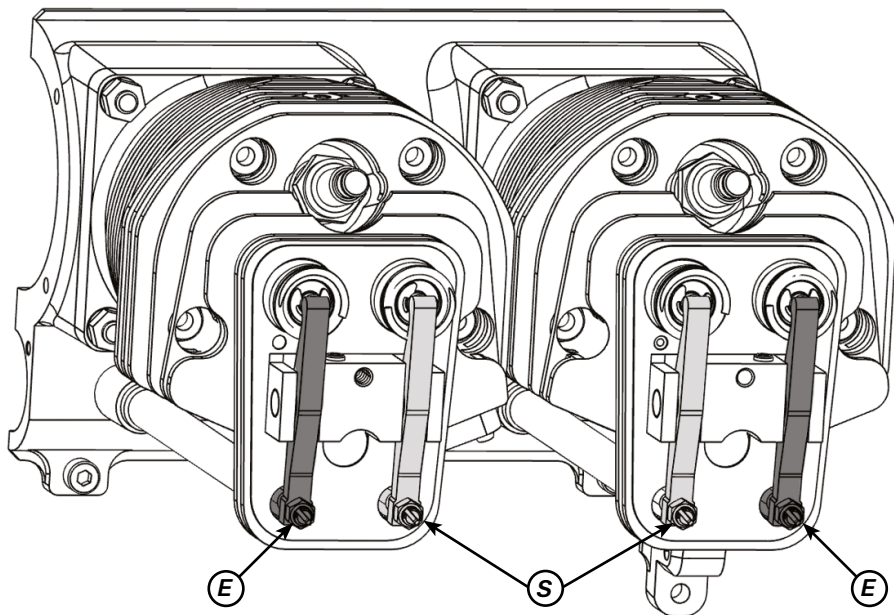

Valves adjustment

- (S) Suction valve 0,1 mm
(E) Exhaust Valve 0,2 mm

Tightening torque

- (1) Spark plug.....20 Nm
(2) Rocker arm cover..... 2,2 Nm
(3) Rocker arm2 Nm

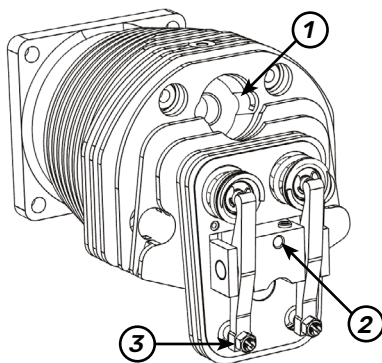

If you have no experience with this type of engine adjustment:

1. Pack the engine and send it to your specialist workshop for adjustment, where they will adjust the engine for you.
2. Ask the manufacturer by email at techinfo@rotomotor.cz

7.2 Carburetor settings

The carburetor is factory adjusted and should NOT need an adjustment before a first flight. Should you wish to adjust the carburetor after the Run-in period and fine tune it to the propeller of your choice, please use the following procedure.

Set the **High needle** „ H “ for the highest RPM. After you are satisfied with High-end, adjust the **Low** „ L “ **needle** for smooth transition between High and Low range without any hesitation.

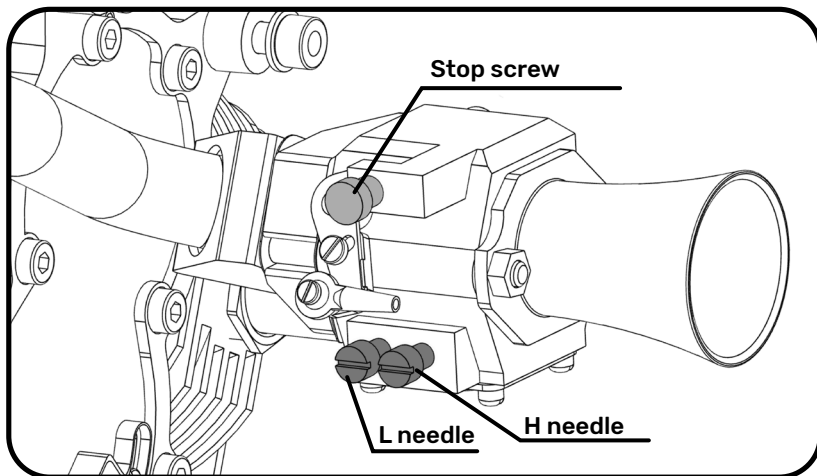

The image is for illustration purposes only



The motor has been adjusted on the bench. Loosen the stop screw to avoid damaging the servo.

ROTO recommends removing the stop screw and maintaining the idle speed with the TX

Adjusting servo / idle

The idle speed is set to 1200 ± 200 RPM by the deflection at the servo.

Then you can remove the stop screw.

How do we know that the engine is set correctly?

With the propeller 28/10 the engine achieves - 5800 ± 200 RPM. When properly adjusted, the engine continuously accelerates from idle speed to maximum. The idle speed with a 28/10 propeller is $1,200 \pm 200$ RPM

These figures may differ when using a different propeller.

8. Starting the engine



Remember to check the correct function of the on-board system before each start by testing the range of the transmitter.

The first way to start:

Will perform a cold start according to the following instructions:



Always check that the ignition is off



Switch on the carburetor choke and, if possible, at the same time plug the carburetor intake with your finger so that the engine intake effect is maximized. Rotate the propeller about ten times and then release the carburetor intake, turn off the choke valve, turn on the ignition and start the engine without the choke. Will only use this when the fuel is first drawn from the tank into the carburetor.

Allow the engine to warm up to operating temperature and run the engine for 15-20 minutes with occasional throttle.

Then fine-tune the carburetor to the exhaust system used and propellers. Use the needle marked „H” to fine-tune the maximum engine power and the second needle with mark „L” to adjust the engine transitions to maximum speed.

The idle speed is set by the throttle servo on the transmitter.

For warm engine starts it is good to use a starting system without a choke



***After flying, do not run out remaining fuel from the aircraft tank.
System will be vented and the engine will start incorrectly.***

9. Spare parts

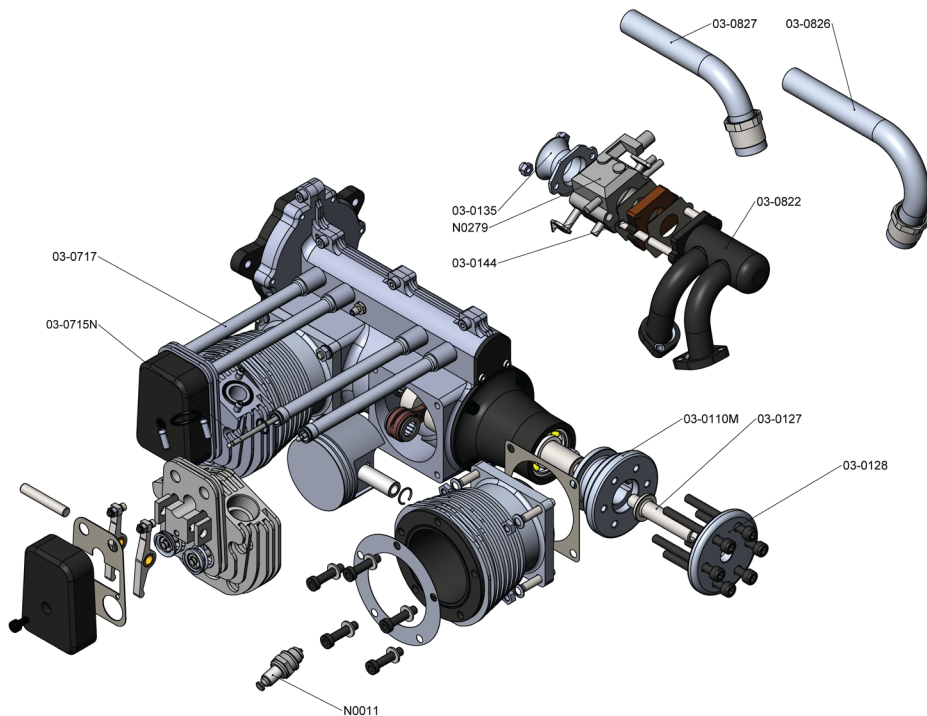

03-0127	Propeller center bolt
03-0128	Propeller washer
03-0135	Air intake - short
03-0144	Carburetor insulator
03-0421	Gasket set
03-0715N	Tappet rod
03-0717	Push rod tube
03-0822	Manifold set
03-0826	Exhaust pipe (front)
03-0827	Exhaust pipe (rear)
08-0010	Ignition system
N0011	Spark plug CM6
N0279	Carburetor
03-0360	Spark plug key

03-0421 Gasket set

- Push rod tube O-ring 8x
- Carburetor gasket 2x
- Rocker cover gasket 2x
- Cylinder gasket 2x
- Cylinder head gasket 2x
- Manifold O-ring 2x

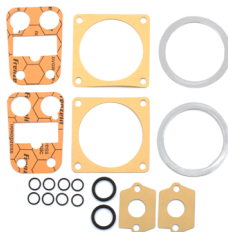

10. Accessories

03-0400A *TS muffler set 85 & 125 FS*

03-0589 *Connector FS 200mm*

03-0596 *Connector FS 300mm*

03-0620 *Muffler STANDARD FS*

06-0110 *Propeller drill jig*



03-0400A



06-0110



03-0589 / 03-0596



03-0620

For more info visit www.rotomotor.cz

11. Warranty card

Name of a product:	
Type:	
Serial number:	
Date of purchase:	
Dealer's name, address:	
Stamp:	

This product has been tested and inspected for sale for 24 months from the date of sale.

The warranty covers defects that occurred during the warranty period due to an error in the production or materials used.

In the event of a defect, please report the product together with the sales document and this, completed and confirmed, warranty card either to the seller or send the product to the manufacturer.

Attach a description of the defect or how it occurred to the warranty claim.

The right to a free warranty repair expires in the following cases:

- ▶ the warranty does not cover defects caused by incorrect installation (eg. incorrect installation, insufficient cooling, etc.)
- ▶ if the data on the warranty card and sales document differ
- ▶ the product has been used for purposes other than those for which it was intended.
- ▶ the warranty does not cover normal wear and tear or unauthorized intervention
- ▶ damage caused by dirt or when electronic or otherwise sensitive parts of the engine come into contact with water or chemicals (eg. paint, cleaning agents, etc.)
- ▶ with regard to a defect caused by mechanical damage to the product (eg. model accident, engine disassembly, etc.)

In the event of an unjustified complaint, the customer will be charged for all costs associated with this complaint, including any repairs.

The costs associated with the transport of goods to the service are borne by the customer

The costs associated with the transport of repaired goods under warranty are borne by the manufacturer. Warranty repairs are performed only by the manufacturer

ROTOmotor accepts no liability for injuries, damage to health or property, when using the engine in violation of the operating instructions manual, the use of common safety principles for the use of the combustion engine and its accessories.

DEVELOPED IN THE CZECH REPUBLIC

 rotomotor@rotomotor.cz

 +420 491 485 100

 www.rotomotor.cz

ROTO engines Ltd.

 Zbecnik 259
Hronov 549 31
Czech Republic

FOLLOW US ON SOCIAL MEDIA

