



TOP FOUR STROKE ENGINES

# ROTO 125 FS

**OPERATING INSTRUCTIONS**



## CONTENTS

<b>1. Introduction</b>	3
<b>2. Safety instructions</b>	3
<b>3. Package contents</b>	4
<b>4. Mounting</b>	5
4.1 The engine mount	5
4.2 The engine	5
4.3 Carburetor	6
4.4 Fuel system	6
4.5 Waste output	7
4.6 Exhaust pipes	7
4.7 Propeller installation	8
<b>5 Ignition</b>	10
5.1 Ignition installation	10
5.2 Ignition power supply	10
<b>6 Engine lubrication</b>	11
<b>7 Settings</b>	12
7.1 The valves adjustment	12
7.2 Carburetor settings	14
<b>8 Starting the engine</b>	15
<b>9 Spare parts</b>	16
<b>10 Accessories</b>	17
<b>11 Warranty card</b>	18
<b>12 Contact / technical support</b>	

Please check the updates of the operating instructions on the website [www.rotomotor.cz](http://www.rotomotor.cz) so that your engine always has the best care.

---

**THANK YOU FOR CHOOSING OUR PRODUCT**

**FOUR-STROKE ENGINE  
PRODUCED IN THE CZECH REPUBLIC.**

---

## **1. Introduction**

---

You have purchased a new four-stroke two-cylinder petrol engine that requires the first few important steps to successfully start your RC plane model .

The engine has already been tested and started by the manufacturer, everything is fine and it works as it should!

The engine is basically adjusted and tested with a 28/10 propeller fitting and ROTO FS exhausts.

## **2. Safety instructions**

---

- Always be very careful when handling the engine.
- The engine can start even when the propeller rotates very slowly and injure you!
- Whenever you start the engine, make sure that you have the model secured so that there is no movement of the model and possible injury!
- Do not drive the plane with the engine running in between spectators and colleagues at the airport!
- Do not touch the engine after the flight, it is hot and there is a risk of burns!
- You have one body, take care of it and enjoy ROTO engines.



**ADVICE**



**WARNING**

## 3. Package contents

*Please follow the instructions carefully.*

*Check that all the listed parts are in the box.*

### Standard package contents:

1. ROTO 125 FS..... 1x
2. Ignition ROTO 125 FS..... 1x
3. Exhaust pipes ..... 2x
4. Waste oil hose ..... 1x
5. Spark plug key CM6..... 1x
6. Cable ties ..... 4x
7. Silicone tubes ..... 2x



## 4. Mounting

### 4.1 The engine mount

To mount the engine in the model, we will use steel strength bolts and lock nuts.

We will use large washers under the nuts due to the pressure distribution on the engine mount, so that mount is not dented.

For the engine to work properly and its properties to be optimal, the engine must be warmed up to operating temperature.

The carburettor is set at the factory (ROTOmotor). We do not recommend any disassembly of the intake manifold or carburetor.



**After mounting the engine firewall occasionally to prevent loosening.**

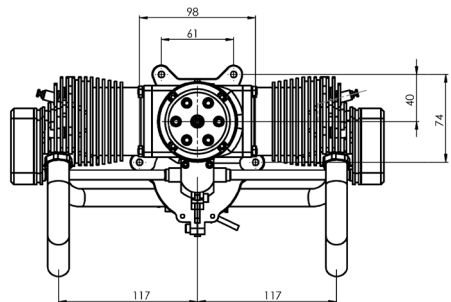
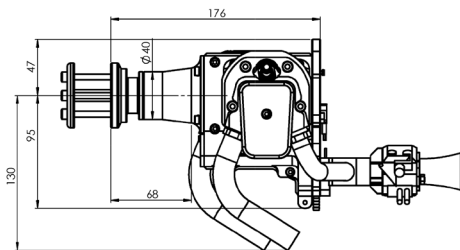

### 4.2 The engine

It is necessary to provide enough air for the supply to the carburetor. In case of lack of air, the engine may have poor performance and may fluctuate at maximum speed.

It is necessary to ensure sufficient cooling of the cylinder heads and cylinders with a constant supply of air from the propeller or from the surrounding environment.

## 4.3 Carburetor

A suction nozzle is mounted on the carburetor. We must ensure a sufficient air supply for the correct operation of the engine. Do not cover it!



**Do not remove the nozzle, do not modify it!**  
**It's part of the engine, and the correct operation of the engine depends on it.**

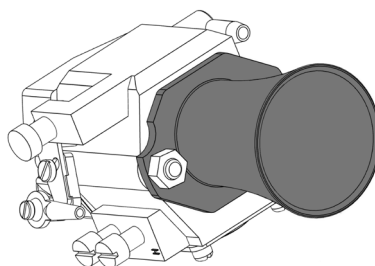

## 4.4 Fuel system

It is necessary to connect a hose with fuel supply to the carburetor. A protective plug is attached to the carburetor fuel fitting due to dirt during transport. This plug must be removed and the gas supply from the model's tank connected in its place.



**When removing the engine from the model for a longer period of time, it is necessary to replace the protective plug to prevent the fuel in the carburetor from drying out.**



**The image is for illustration purposes only**

## 4.5 Waste output

Then install the lubrication waste oil hose on the rear cover of the engine. To seal it we use Loctite 326 glue or similar to seal the thread.

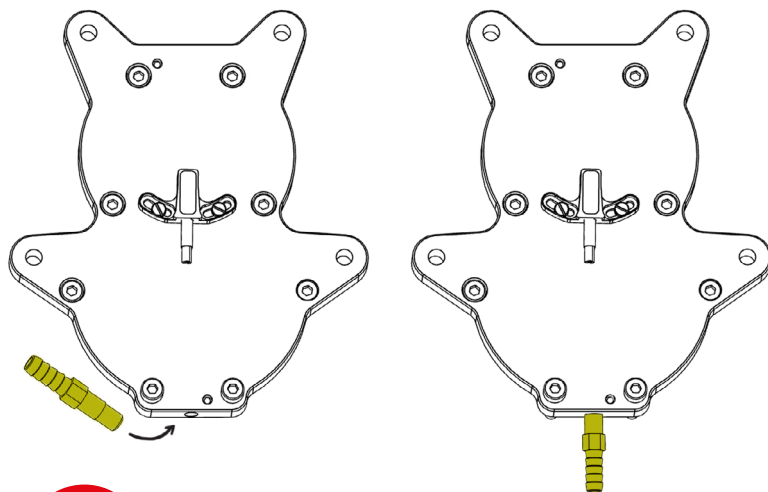

NO TOOLS



ONLY HAND



LOCTITE 326



WAIT  
3HOURS

***We recommend leading the waste oil hose to the landing gear.***



***Waste output is very important and must never be blocked.***

***In any case do not reduce the diameter of the hose, or it will damage the engine.***

***If the waste output was clogged, the motor will be damaged.***

## 4.6 Exhaust pipes

The exhaust pipes are made so that they can be rotated around the axis. Therefore, set the exhaust pipes to the desired position by turning and then secure by tightening the nut.



**The diameter of the exhaust pipe cannot be reduced!**



**Beware of damage to the end of the pipe!**  
**The end of the pipe serves as a sealing surface for the extension tube. If damaged, it will not be possible to seal the pipes correctly!**

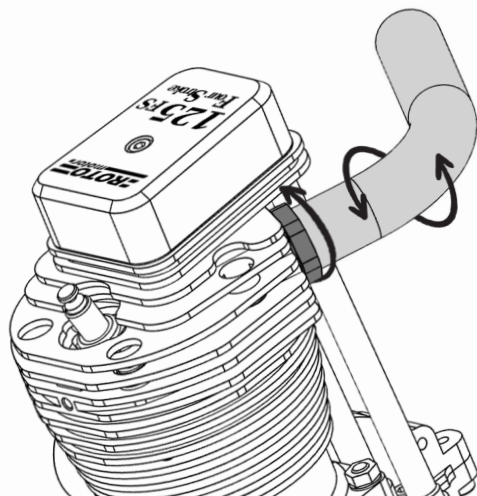

The exhaust pipes can be rotated in a small range as needed.

$\pm 10^\circ$

**Silicone pipes\*** are used to seal the transition between the exhaust pipes and the ROTO exhausts, or between the extension pipe and the ROTO FS exhaust.

### **ROTO extension pipe and exhaust not included!**

When mounting on the extension pipe or exhaust, the **silicone pipe\*** must be secured with a **cable tie\*** on each side of the hose to seal the connection well.



**The silicone pipe seals correctly only if the contact surfaces are clean and free of grease.**

**When reassembling, the contact surfaces must be degreased!**



**There should be no more than 2mm between the end of the exhaust pipe and the exhaust.**

\*A part of the package



## 4.7 Propeller installation

It is very important to mount the propeller correctly. 6 strength screws are used for this purpose. Tighten them evenly! The propeller must be regularly checked and tightened, especially when using a new wooden propeller.

### Tightening torque

Carbon propeller ..... 7 Nm  
Wooden propeller..... 6 Nm

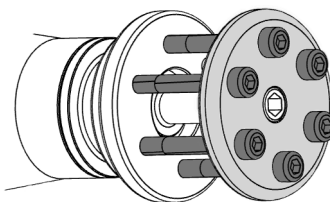

*For wooden propellers, the tightening torque may vary based on the material used to make the propellers. We recommend asking the propeller manufacturer for the appropriate tightening torque!*



*Check the tightening of the propeller often, especially at beginning, when the propeller is new!*



*Loose screws will cause the screws cuts to, exposing you to the risk of injury as well as damage to your model. This danger is mainly posed by the use of a wooden propeller.*

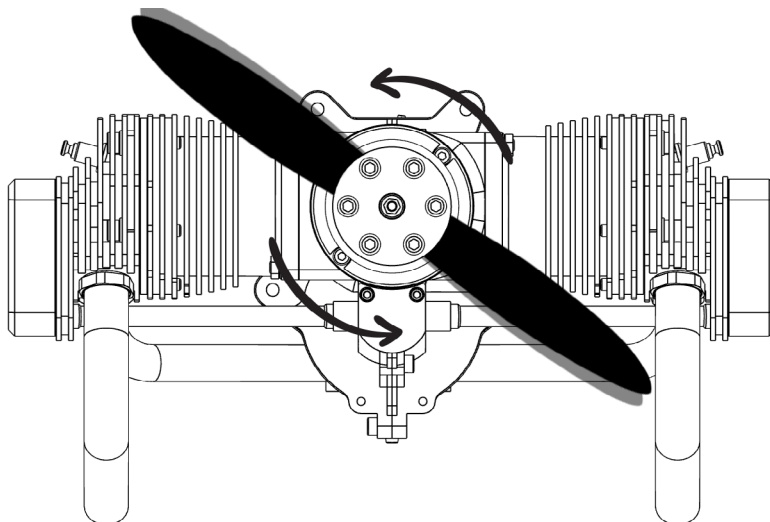

**Direction of rotation of the propeller / Engine**

## 5. Ignition

### 5.1 Ignition installation

Ignition installation is an integral part of installing an engine in an aircraft.

Place the ignition in a suitable place where there is no risk of excessive heat from the cylinder heads or the exhaust system.

If the ignition is heated above 60 °C, the ignition will be switched off and the engine stops working.



**Never remove the Hall sensors from the backplate.**



**Make sure that the ignition is well and sufficiently cooled!**

Install the spark plug cup from the ignition to the spark plugs.

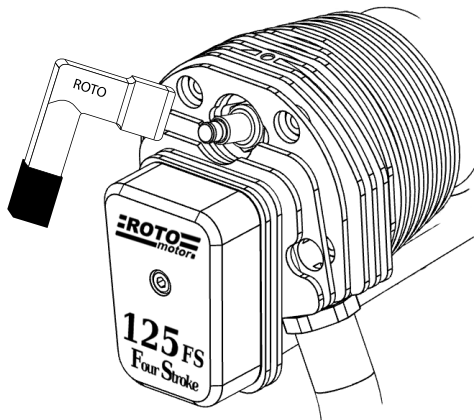

**Make sure that the connectors are fitted correctly and that there is no risk of loosening them!**

**Do not bend the HV cables into sharp bends, they may be interrupted!**

### 5.2 Ignition power supply

The recommended power supply for ignition is 4-9V.



**Always charge the batteries before flying.  
Do not rely on charging from the last flight!**

## 6. Engine lubrication

Engine lubrication is provided by adding oil to gasoline in a ratio of 1:50.  
For easier application, use this table:

Use gasoline **95 - 98 okt.**  
+  
**Motul 800** oil /1:50 *or* **STIHL HP Ultra** oil /1:50



**Failure to follow the recommended oil types will void your warranty.  
! DANGER OF ENGINE DAMAGE!**

### Metric system

Fuel	Oil
L	ml
1	20
2	40
3	60
4	80
5	100
6	120

### Imperial system

Fuel	Oil
gal	oz
1	2.56
2	5.12
3	7.68
4	10.24
5	12.8
6	15.36



**Information about our network of dealers at [info@rotomotor.cz](mailto:info@rotomotor.cz)**

## 7. Settings

### 7.1 The valves adjustment

For the operation and long-term operation of the engine, the correct valve clearance must be checked after the **first 2-3 hours of operation**.

**Follow these steps to check and adjust:**

Unscrew the rocker arm cover bolts on the cylinder heads and then remove the rocker arm covers. Adjust the piston to the top dead center so that the mark on the propeller hub is in alignment with the crankcase dividing plane of the engine on the top of the engine.

Then start adjusting the clearances on the side where the valves are not cut shear! This means where there is a slight clearance on both rockers.

**Valves adjustment:**

Loosen the lock nut with a wrench and turn the screw. Set the required clearance with the help of a feeler gauge.

Then tighten the lock nut again and proceed to adjust the second valve.

Repeat this on the other side of the engine, turning the crankshaft 360 °.

Then complete the engine.

 **Rotates counterclockwise**

Now the rocker arm clearance is adjusted. Future adjustments are only necessary when disassembling certain important parts.

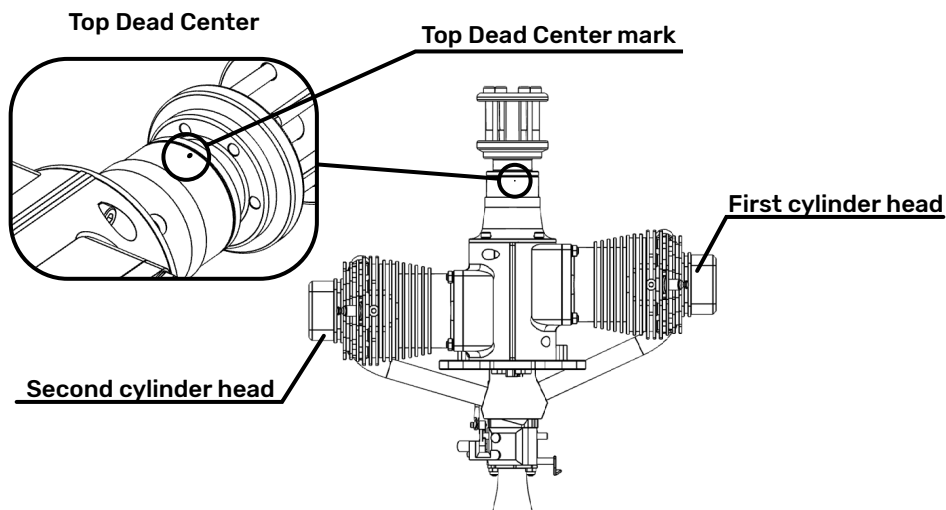

## Adjusting the first cylinder head

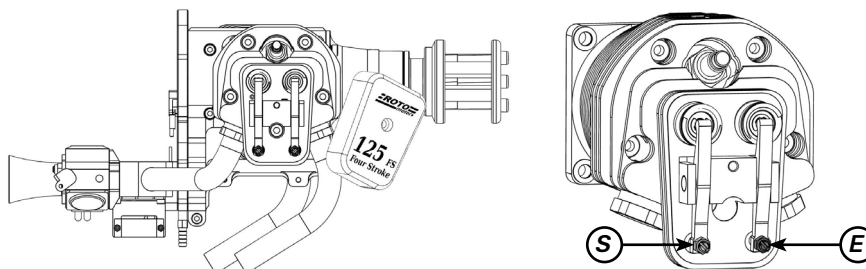

## Adjusting the second cylinder head

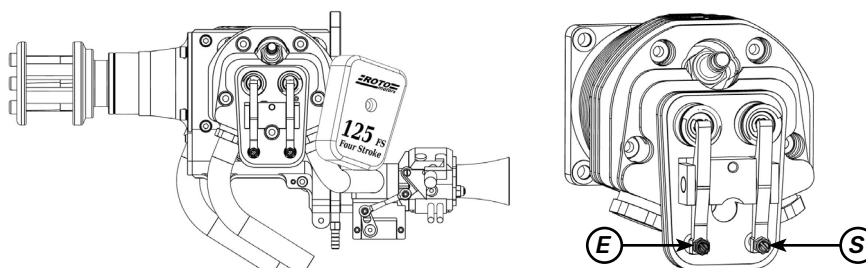

### Valves adjustment

- Ⓢ Suction valve ..... 0,1 mm
- ⓔ Exhaust Valve ..... 0,2 mm

### Tightening torque

- ① Spark plug.....20 Nm
- ② Rocker arm cover.....2,2 Nm
- ③ Rocker arm .....2 Nm
- ④ Cylinder head.....5 Nm

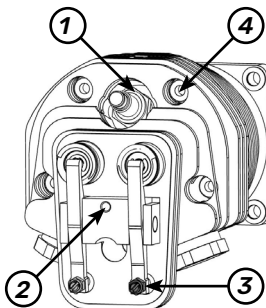

If you have no experience with this type of engine adjustment:

1. Pack the engine and send it for adjustment to your specialist garage, where the engine will be adjusted for you.
2. Ask the manufacturer by email at [techinfo@rotomotor.cz](mailto:techinfo@rotomotor.cz)

## 7.2 Carburetor settings

The carburetor is factory adjusted and should NOT need an adjustment before a first flight. Should you wish to adjust the carburetor after the Run-in period and fine tune it to the prop of your choice, please use the following procedure.

Set the **High needle „ H „** for the highest RPM. After you are satisfied with High-end, adjust the **Low „ L „ needle** for smooth transition between High and Low range with out any hesitation.

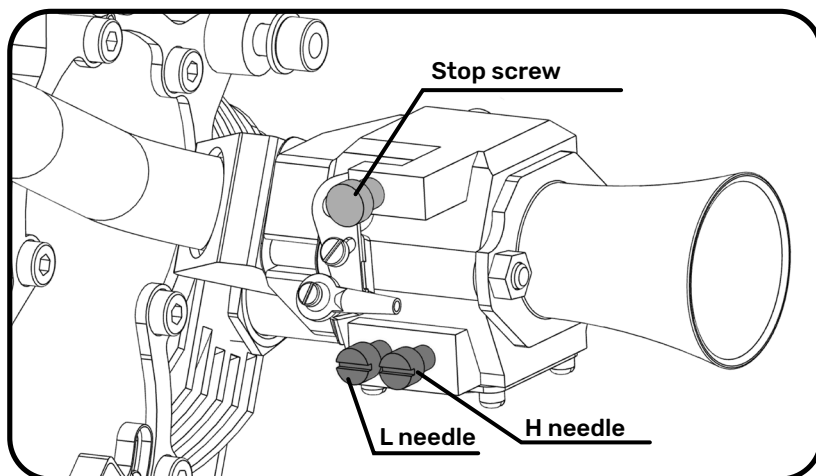

*The image is for illustration purposes only*



***The motor has been adjusted on the bench. Must be loosen the stop screw to avoid damaging the servo.***

***ROTO recommends removing Stop Screw and idle rpm keep by your TX***

### **Adjusting servo / idle**

The idle speed is set to  $1200 \pm 200$  RPM by the deflection at the servo.

***Then you can remove the stop screw.***

### **How do we know that the engine is set correctly?**

With the propeller 28/10 the engine achieves -  $5800 \pm 200$  RPM. When properly adjusted, the engine continuously accelerates from idle speed to maximum. The idle speed with a 28/10 propeller is  $1,200 \pm 200$  RPM

***These figures may differ when using a different propeller.***

## 8. Starting the engine



Remember to check the correct function of the on-board system before each start by testing the range of the transmitter.

### The first way to start:

***We will perform a cold start according to the following instructions:***



**Always check that the ignition is off**



Switch on the carburettor choke and, if possible, at the same time plug the carburettor intake with your finger so that the engine intake effect is maximized. Rotate the propeller about ten times and then release the carburettor intake, turn off the choke valve, turn on the ignition and start the engine without the choke. We will only use this when the fuel is first drawn from the tank into the carburetor.

Allow the engine to warm up to operating temperature and run the engine for 15-20 minutes with occasional throttle.

Then fine-tune the carburetor to the exhaust system used and propellers. Use the needle marked „H” to fine-tune the maximum engine power and the second needle with mark „L” to adjust the engine transitions to maximum speed.

The idle speed is set by the throttle servo on the transmitter.

***For warm engine starts it is good to use a starting system without a choke***



***After flying, do not run out remaining fuel from the aircraft tank.  
System will be vented and the engine will start incorrectly.***

## 9. Spare parts

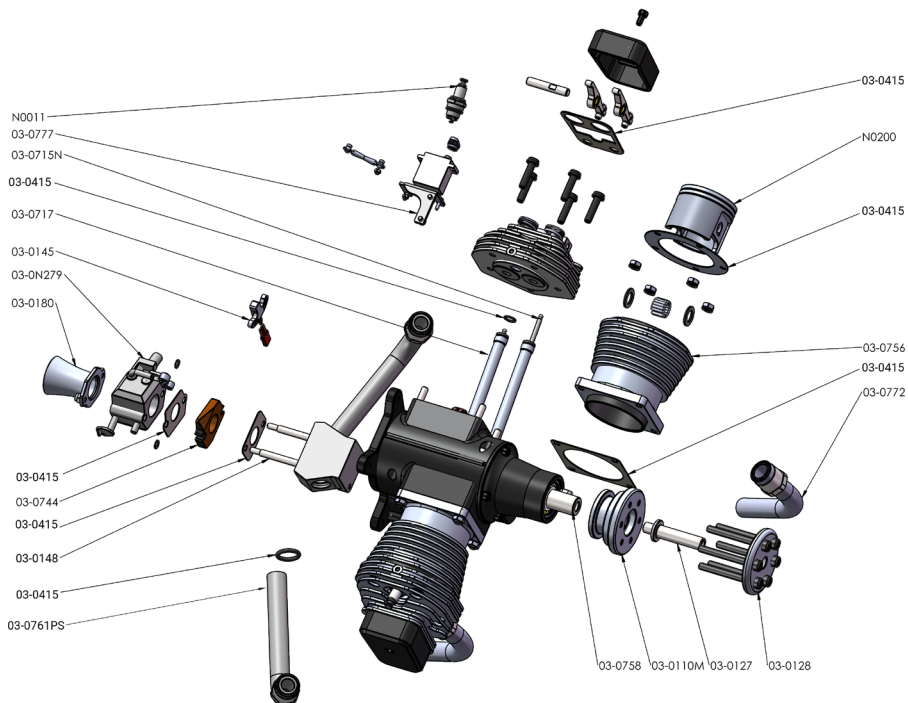

03-0127	.....	Propeller center bolt
03-0128	.....	Prop washer
03-0148	.....	Carburetor bolt
03-0180	.....	Air intake - long
03-0415	.....	Gasket set
03-0715n	.....	Tappet rod
03-0744	.....	Carburetor insulator
03-0148	.....	Carburetor bolt
03-0761PS	.....	Mainfold
03-0772	.....	Exhaust pipe
03-0777	.....	Sawox servo holder
03-0780	.....	Choke control lever
08-0008	.....	Ignition system
N0011	.....	Spark plug CM6
N0279	.....	Carburetor
03-0360	.....	Spark plug key



03-0415 ..... Gasket set

- Push rod tube O-ring ..... 8x
- Carburetor gasket ..... 2x
- Rocker cover gasket ..... 2x
- Cylinder gasket ..... 2x
- Cylinder head gasket ..... 2x
- Manifold O-ring ..... 2x

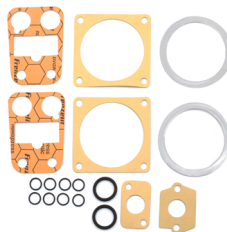

## 10. Accessories

03-0400A ..... *TS muffler set 85 & 125 FS*

03-0589 ..... *Connector FS 200mm*

03-0596 ..... *Connector FS 300mm*

03-0620 ..... *Muffler STANDARD FS*

06-0110 ..... *Propeller drill jig*



**TS muffler set 85 & 125 FS**



**Propeller drill jig**



**Connector FS 200 & 300**



**Muffler STANDARD FS**

**For more info visit [www.rotomotor.cz](http://www.rotomotor.cz)**

## 11. Warranty card

<b>Name of a product:</b>	
<b>Type:</b>	
<b>Serial number:</b>	
<b>Date of purchase:</b>	
<b>Dealer's name, address:</b>	
<b>Stamp:</b>	

This product has been tested, inspected and inspected for sale for 24 months from the date of sale.

The warranty covers defects that occurred during the warranty period due to an error in the production or materials used.

In the event of a defect, please report the product together with the sales document and this, completed and confirmed, warranty card either to the seller or send the product to the manufacturer.

Attach a description of the defect or how it occurred to the warranty claim.

### **The right to a free warranty repair expires in the following cases:**

- ▶ the warranty does not cover defects caused by incorrect installation (eg incorrect installation, insufficient cooling, etc.)
- ▶ if the data on the warranty card and sales document differ
- ▶ the product has been used for purposes other than those for which it was intended.
- ▶ the warranty does not cover normal wear and tear or unauthorized intervention
- ▶ damage caused by dirt or when electronic or otherwise sensitive parts of the engine come into contact with water or chemicals (eg paint, cleaning agents, etc.)
- ▶ with regard to a defect caused by mechanical damage to the product (eg model accident, engine disassembly, etc.)

In the event of an unjustified complaint, the customer will be charged for all costs associated with this complaint, including any repairs.

The costs associated with the transport of goods to the service are borne by the customer

The costs associated with the transport of repaired goods under warranty are borne by the manufacturer. Warranty repairs are performed only by the manufacturer

***ROTOmotor accepts no liability for injuries, damage to health or property, when using the engine in violation of the operating instructions manual, the use of common safety principles for the use of the combustion engine and its accessories.***

# DEVELOPED IN THE CZECH REPUBLIC

---

 [rotomotor@rotomotor.cz](mailto:rotomotor@rotomotor.cz)

 +420 491 485 100

 [www.rotomotor.cz](http://www.rotomotor.cz)

***ROTO engines Ltd.***

 Zbecnik 259  
Hronov 549 31  
Czech Republic

---

FOLLOW US ON SOCIAL MEDIA

